



US008754706B2

(12) **United States Patent**
Gudem et al.

(10) **Patent No.:** **US 8,754,706 B2**
(45) **Date of Patent:** **Jun. 17, 2014**

(54) **POWER BASED FEEDBACK FOR IMPROVED POWER AMPLIFIER (PA) EFFICIENCY**

(75) Inventors: **Prasad Srinivasa Siva Gudem**, San Diego, CA (US); **Ketan Humnabadkar**, San Diego, CA (US); **Vijay K. Chellappa**, San Diego, CA (US); **Sumit Verma**, San Diego, CA (US)

(73) Assignee: **QUALCOMM Incorporated**, San Diego, CA (US)

(*) Notice: Subject to any disclaimer, the term of this patent is extended or adjusted under 35 U.S.C. 154(b) by 65 days.

6,141,541 A	10/2000	Midya et al.	
6,191,653 B1 *	2/2001	Camp et al.	330/129
6,531,860 B1	3/2003	Zhou et al.	
6,646,501 B1	11/2003	Wessel	
6,987,417 B2	1/2006	Winter et al.	
7,026,868 B2	4/2006	Robinson et al.	
7,183,856 B2	2/2007	Miki et al.	
7,333,563 B2	2/2008	Chan et al.	
7,346,122 B1	3/2008	Cao	
7,427,897 B2	9/2008	Hau et al.	
7,741,903 B2	6/2010	Vinayak et al.	
7,741,906 B1	6/2010	Summerfield	
7,830,220 B2	11/2010	Ceylan et al.	
8,093,946 B2	1/2012	Wimpeny et al.	

(Continued)

FOREIGN PATENT DOCUMENTS

WO WO-0030250 A1 5/2000

OTHER PUBLICATIONS

Chung S. et al., "Asymmetric Multilevel Out phasing Architecture for Multi-Standard Transmitters", Radio Frequency Integrated Circuits Symposium, 2009. RFIC 2009. IEEE, IEEE, Piscataway, NJ, USA, Jun. 7, 2009, pp. 237-240, XP031480266, ISBN: 978-1-4244-3377-3.

(Continued)

Primary Examiner — Steven J Mottola
(74) Attorney, Agent, or Firm — Linda G. Gunderson

(57) **ABSTRACT**

A power train amplification stage is described. The power train amplification stage includes a power amplifier. The power train amplification stage also includes a switched mode power supply that provides a bias voltage to the power amplifier. The power train amplification stage further includes a pulse density modulator. The power train amplification stage also includes a feedback path from the power amplifier to the pulse density modulator.

20 Claims, 10 Drawing Sheets

(21) Appl. No.: **13/490,707**

(22) Filed: **Jun. 7, 2012**

(65) **Prior Publication Data**

US 2013/0033314 A1 Feb. 7, 2013

Related U.S. Application Data

(60) Provisional application No. 61/514,262, filed on Aug. 2, 2011.

(51) **Int. Cl.**
H03G 3/20 (2006.01)

(52) **U.S. Cl.**
USPC **330/127**

(58) **Field of Classification Search**
USPC 330/127, 297; 455/127.1
See application file for complete search history.

(56) **References Cited**

U.S. PATENT DOCUMENTS

5,892,404 A	4/1999	Tang
6,043,707 A	3/2000	Budnik

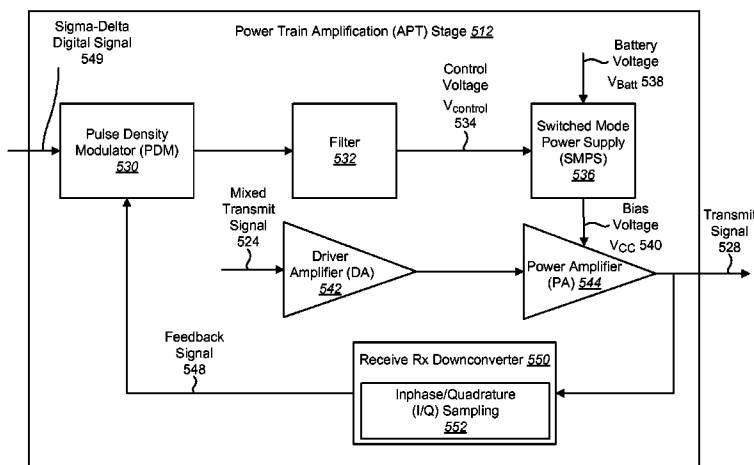

(56)

References Cited

U.S. PATENT DOCUMENTS

8,160,519 B2 4/2012 Nentwig
2008/0258831 A1 10/2008 Kunihiro et al.
2009/0054018 A1 2/2009 Waheed et al.
2010/0176885 A1 7/2010 Kim et al.
2011/0063026 A1 3/2011 Jung et al.
2011/0298539 A1 12/2011 Drogi et al.

OTHER PUBLICATIONS

Hammi, et al., "On the Robustness of Digital Predistortion Function Synthesis and Average Power Tracking for Highly Nonlinear Power Amplifiers," IEEE Transactions on Microwave Theory and Techniques, vol. 55, Issue 6, pp. 1382-1389, 2007.

Idris, et al., "Design and Implementation of Self-Calibration for Digital Predistortion of Power Amplifiers," WSEAS Transactions on Circuits and Systems, vol. 7, Issue 2, pp. 75-84, 2008.

International Search Report and Written Opinion—PCT/US2012/049403—ISA/EPO—Jan. 14, 2013.

Tenbroek, et al., "Single-Chip Tri-Band WCDMA/HSDPA Transceiver without External SAW Filters and with Integrated Tx Power Control," 2008 IEEE International Solid-State Circuits Conference (Paper).

Tenbroek, et al., "Single-Chip Tri-Band WCDMA/HSDPA Transceiver without External SAW Filters and with Integrated Tx Power Control," 2008 IEEE International Solid-State Circuits Conference (Powerpoint Presentation).

* cited by examiner

100

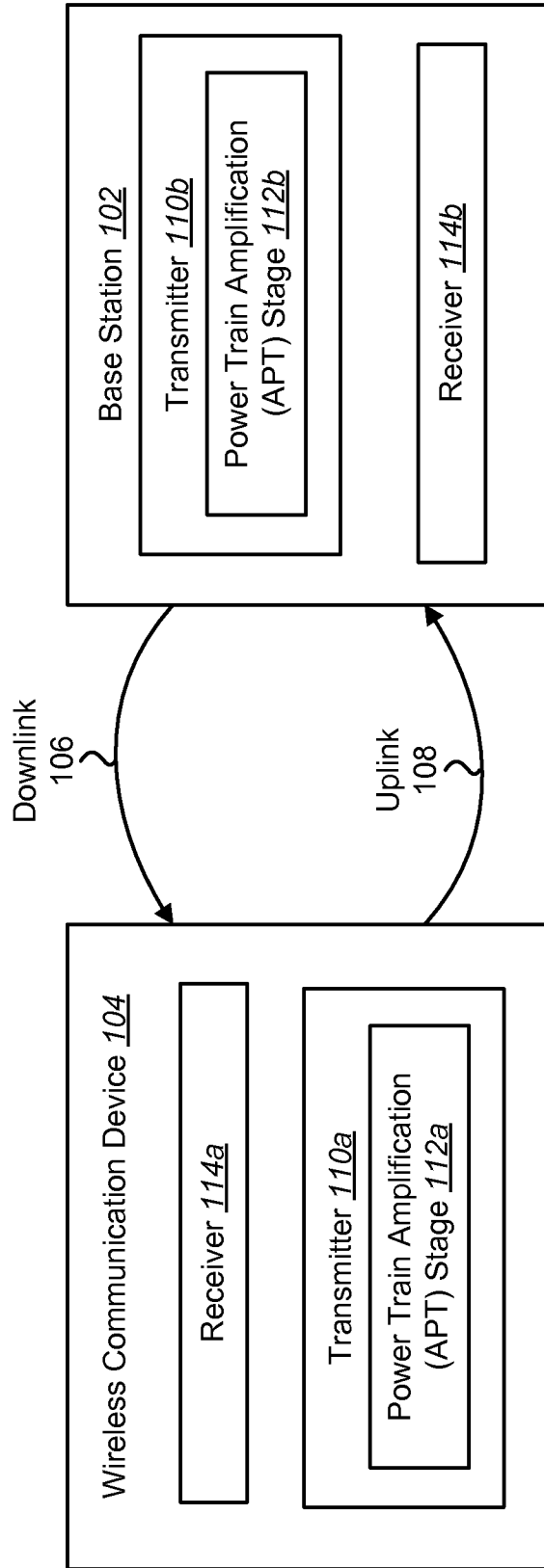

FIG. 1

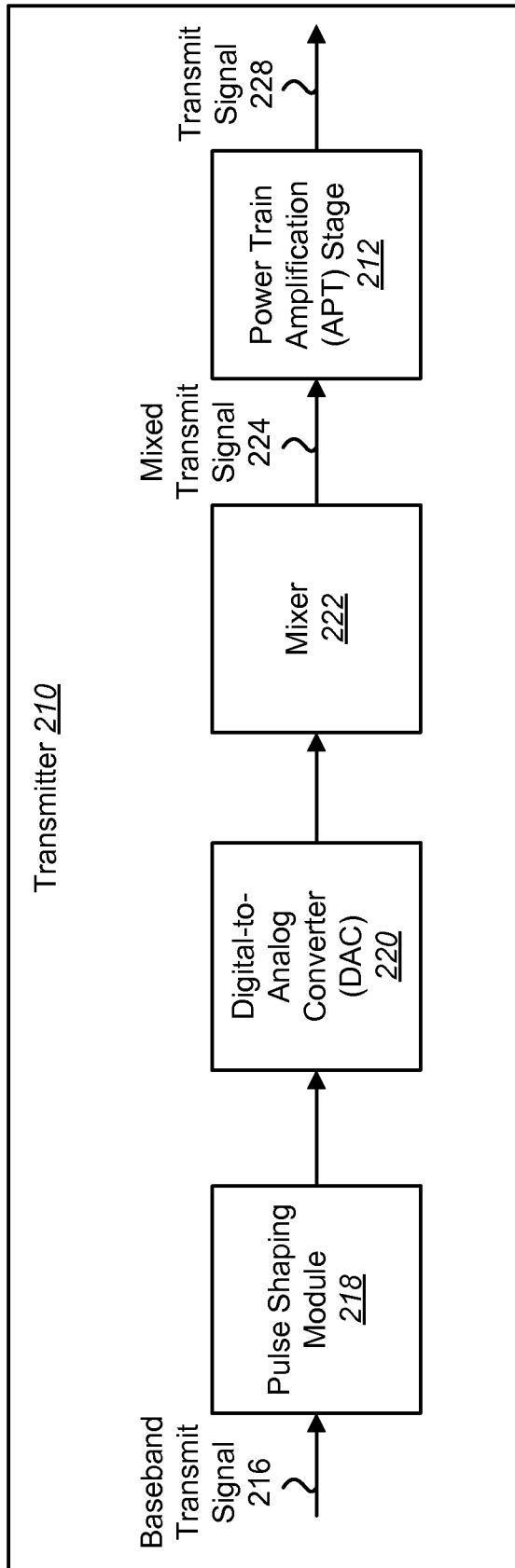

FIG. 2

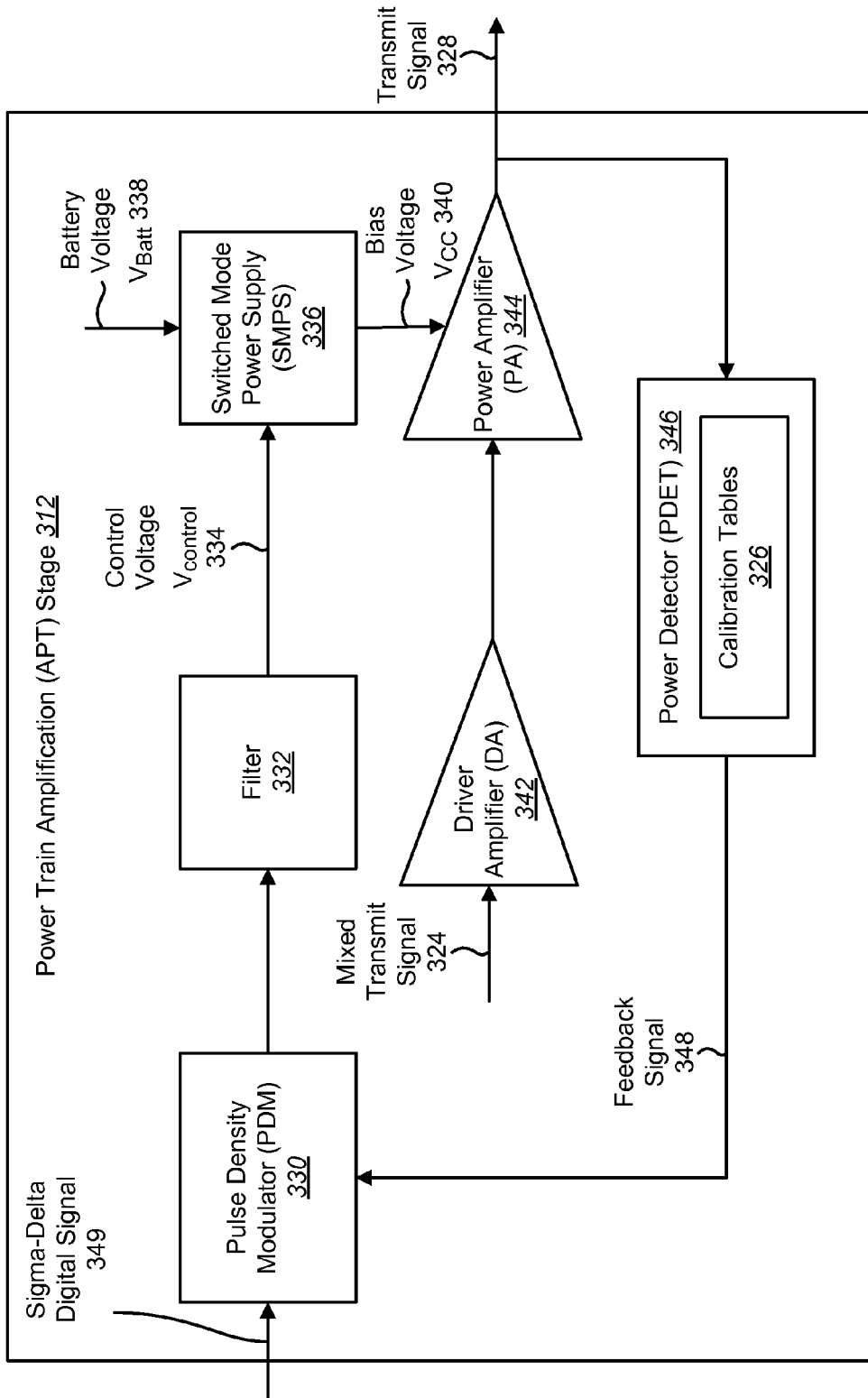

FIG. 3

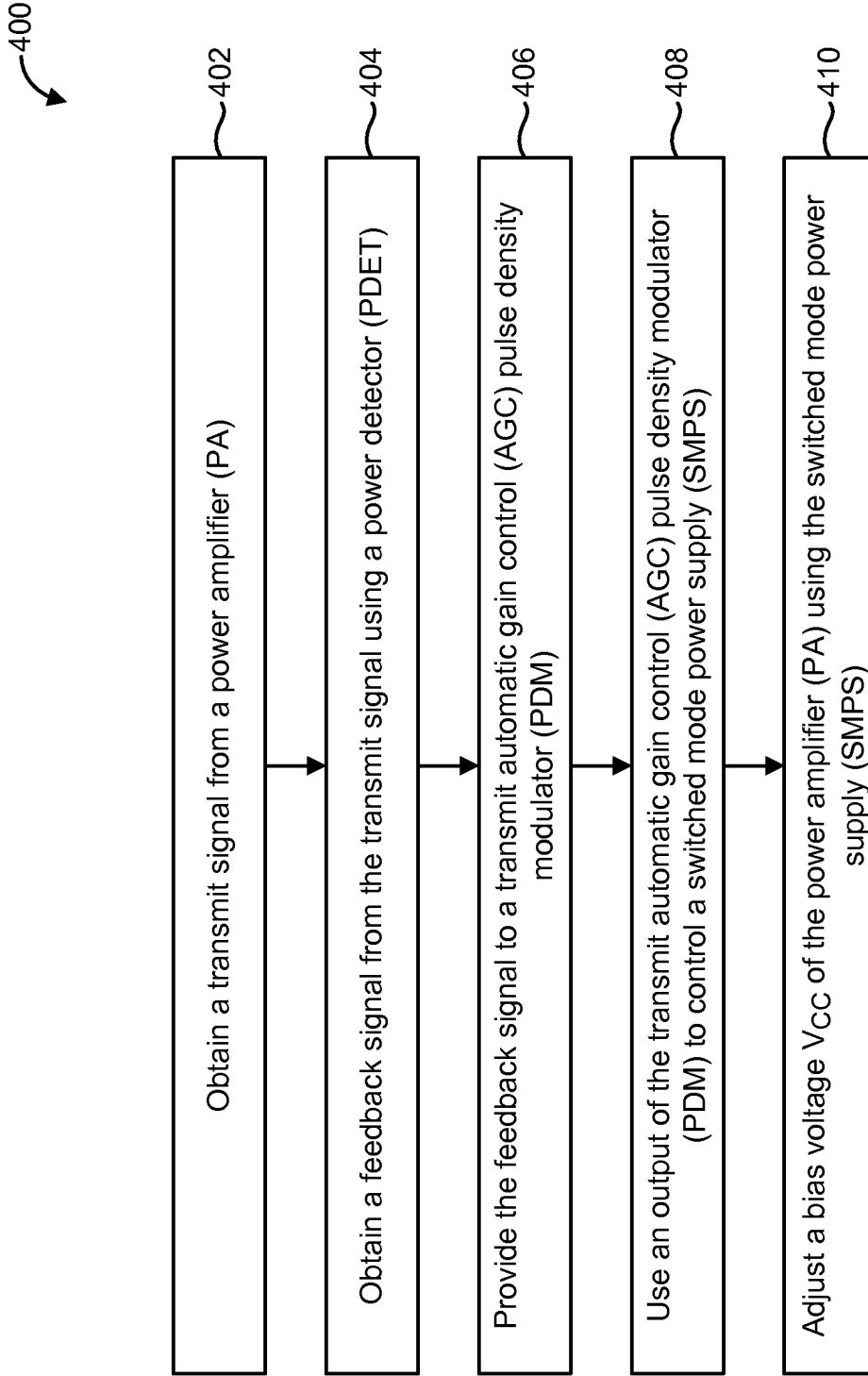

FIG. 4

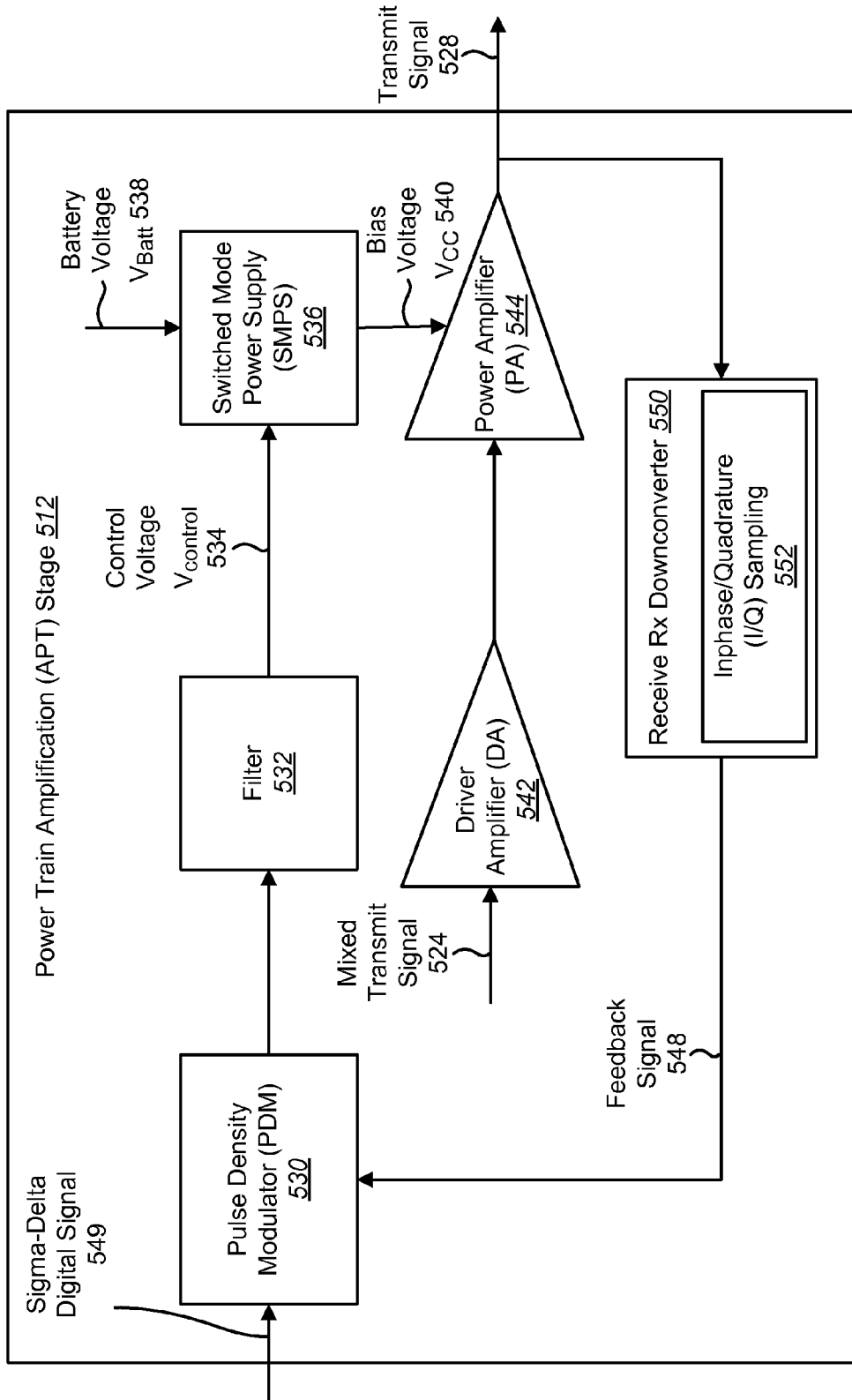

FIG. 5

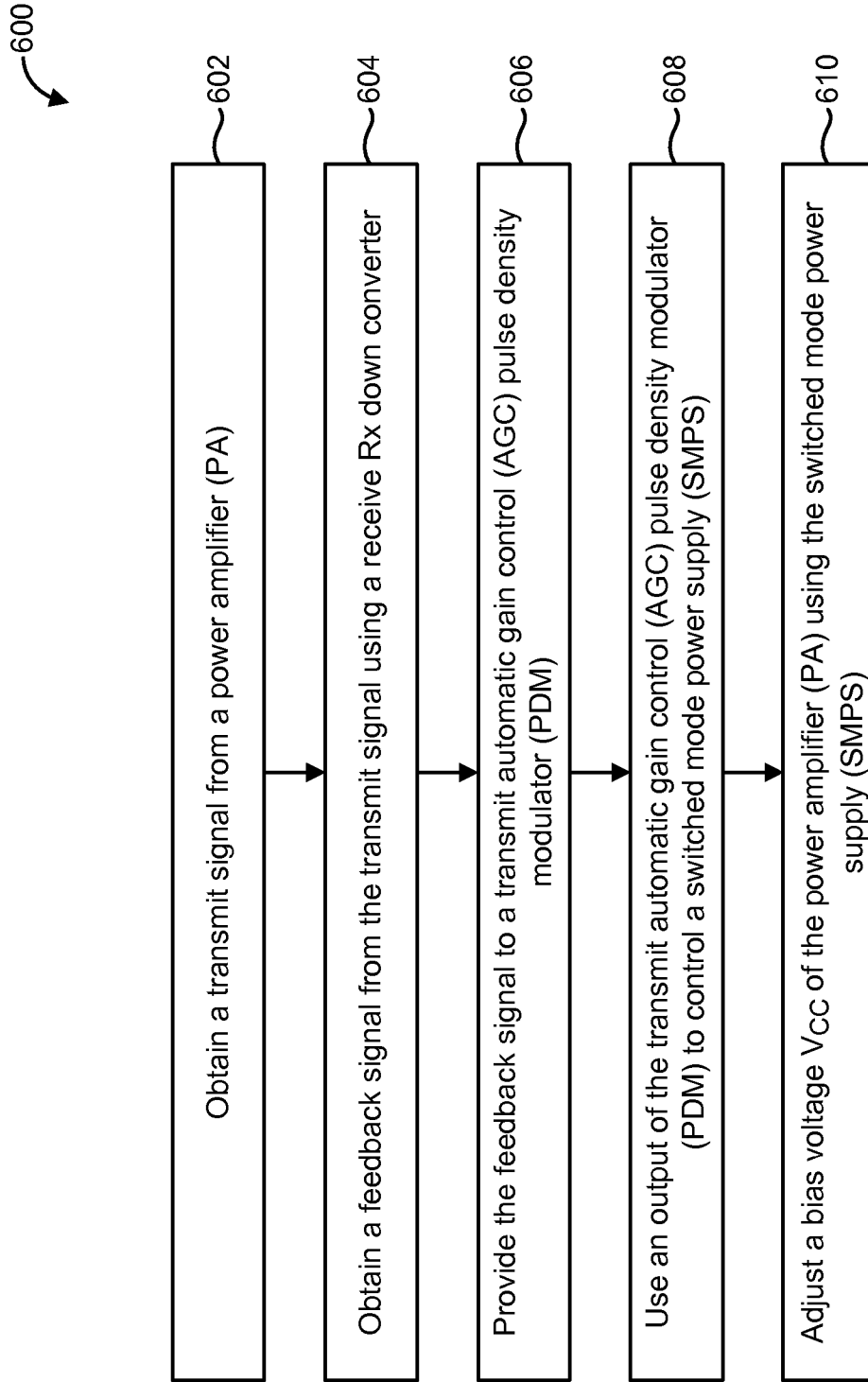

FIG. 6

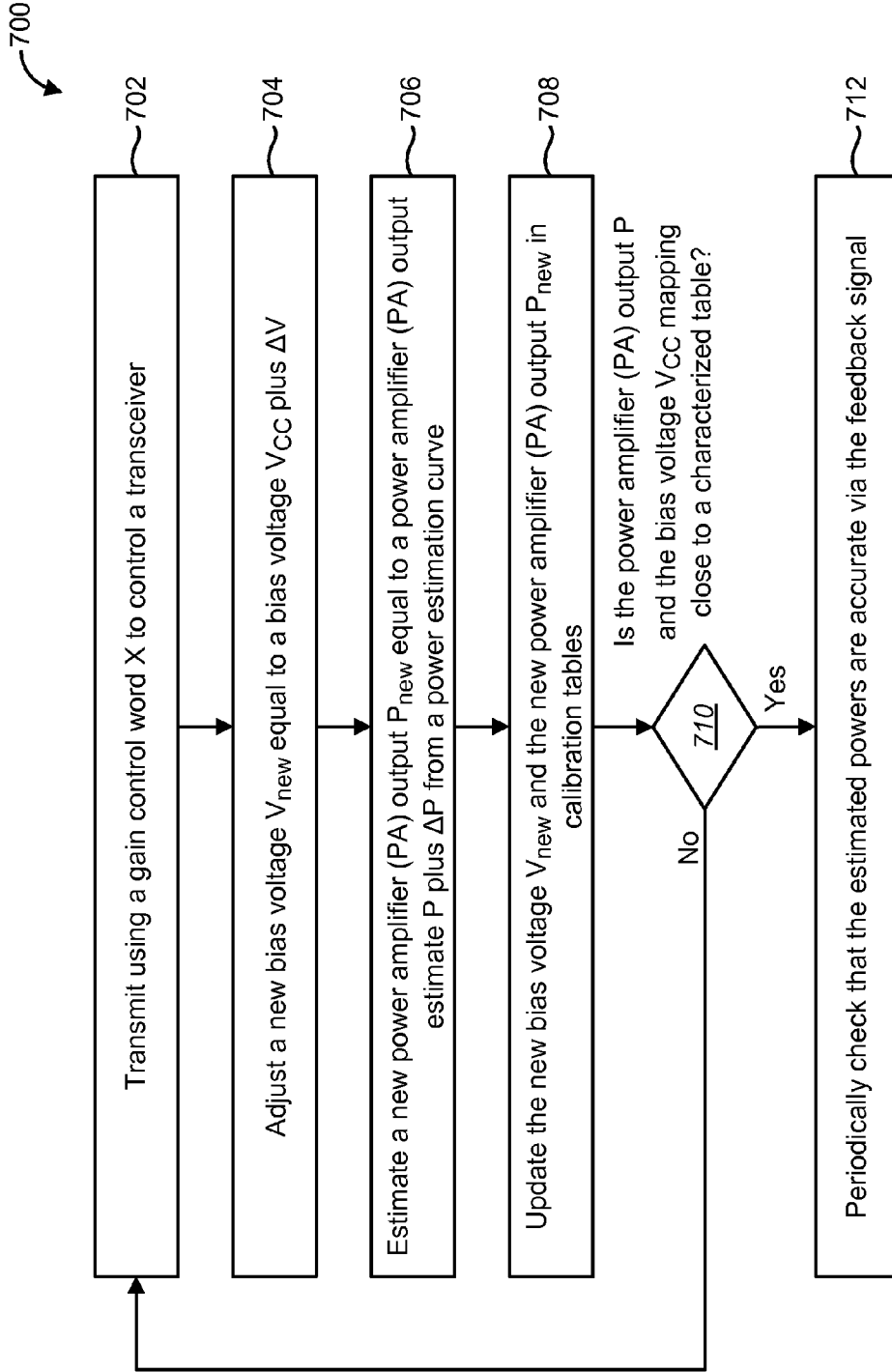

FIG. 7

800

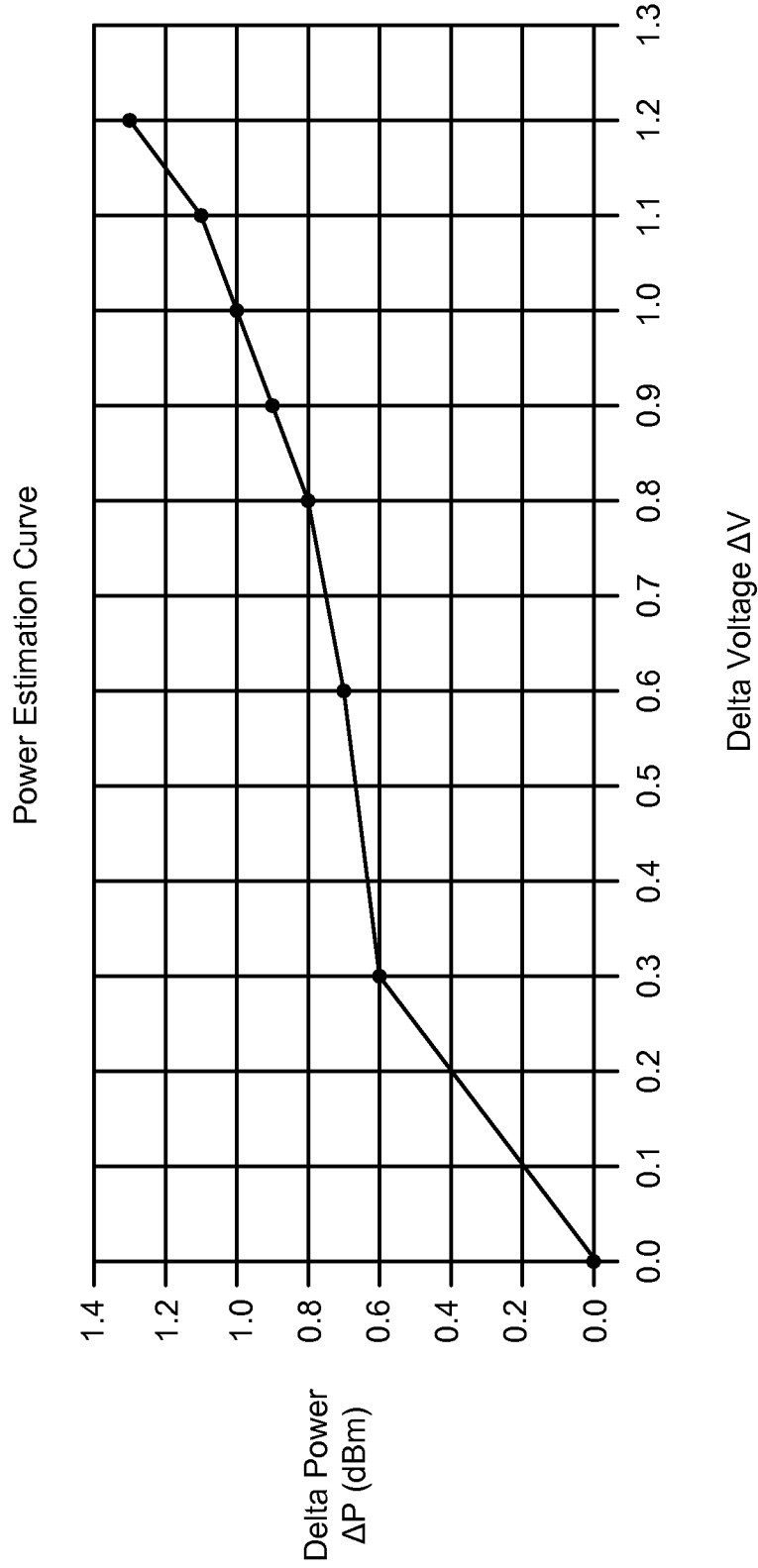

FIG. 8

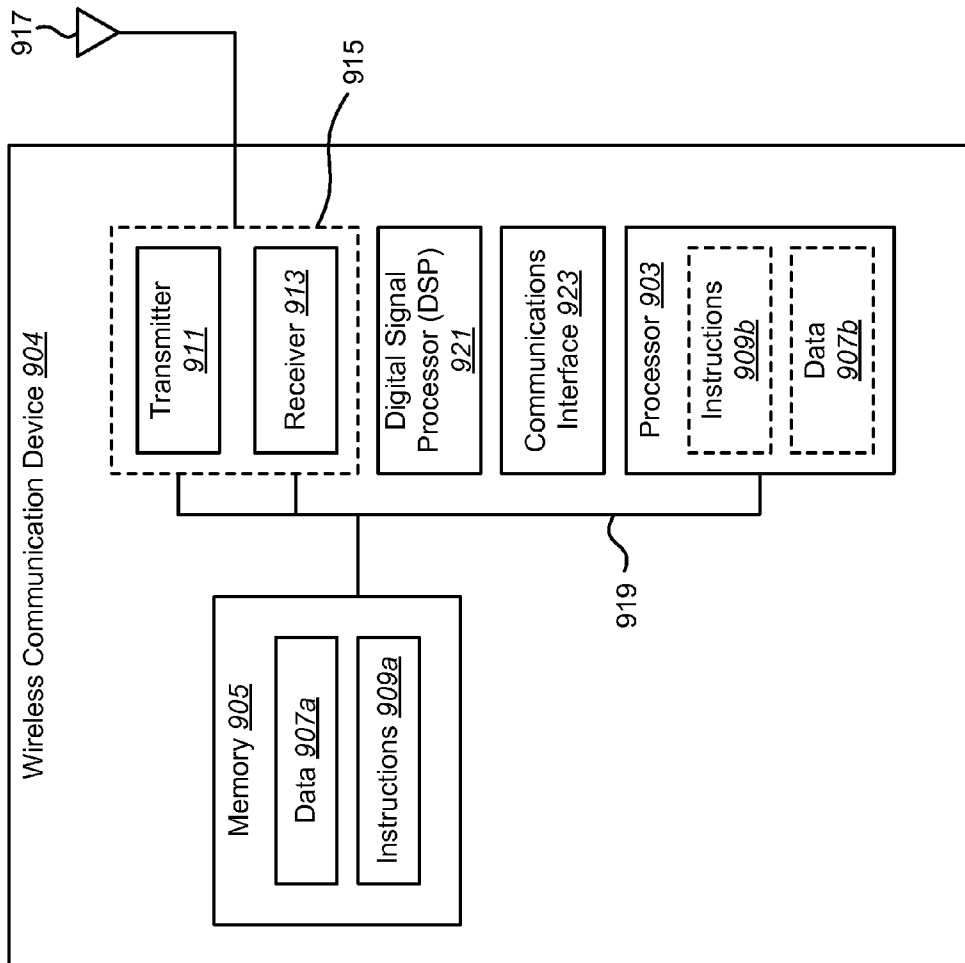

FIG. 9

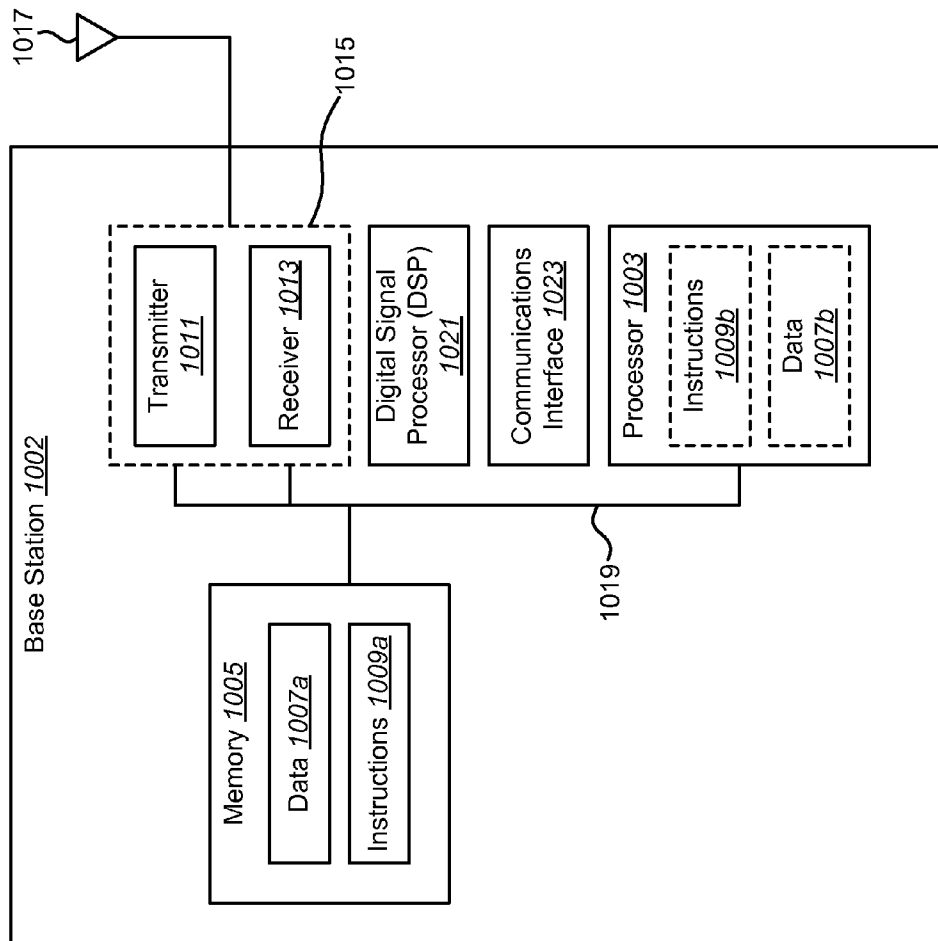

FIG. 10

POWER BASED FEEDBACK FOR IMPROVED POWER AMPLIFIER (PA) EFFICIENCY

CLAIM OF PRIORITY UNDER 35 U.S.C. §119

The present Application for Patent claims priority to Provisional Application No. 61/514,262, entitled "DEVICES AND METHODS FOR FEEDBACK-BASED POWER AMPLIFIER COLLECTOR VOLTAGE CONTROL" filed Aug. 2, 2011, and assigned to the assignee hereof and hereby expressly incorporated by reference herein.

TECHNICAL FIELD

The present disclosure relates generally to wireless devices for communication systems. More specifically, the present disclosure relates to systems and methods for power based feedback for improved power amplifier (PA) efficiency.

BACKGROUND

Electronic devices (cellular telephones, wireless modems, computers, digital music players, Global Positioning System units, Personal Digital Assistants, gaming devices, etc.) have become a part of everyday life. Small computing devices are now placed in everything from automobiles to housing locks. The complexity of electronic devices has increased dramatically in the last few years. For example, many electronic devices have one or more processors that help control the device, as well as a number of digital circuits to support the processor and other parts of the device.

These electronic devices may communicate wirelessly with each other and with a network. As the demand for information by these electronic devices has increased, the downlink throughput has also increased. One such way to increase downlink throughput is the use of carrier aggregation. In carrier aggregation, multiple carriers may be aggregated on the physical layer to provide the required bandwidth (and thus the required throughput).

It may be desirable for an electronic device to maximize battery life. Because an electronic device often runs on a battery with a limited operation time, reductions in the power consumption of an electronic device may increase the desirability and functionality of the electronic device.

SUMMARY

A power train amplification stage is described. The power train amplification stage includes a power amplifier, a switched mode power supply that provides a bias voltage to the power amplifier, a pulse density modulator and a feedback path from the power amplifier to the pulse density modulator.

The pulse density modulator may control the switched mode power supply. The pulse density modulator may receive a sigma-delta digital signal. The feedback path may include a power detector. Calibration tables for the power amplifier may be maintained in baseband memory. The power detector may be continuously monitored in online mode to keep updating the bias voltage for the power amplifier.

The power train amplification stage may use dynamic voltage scaling to reduce inefficiencies in the power amplifier. The inefficiencies may include at least one of a frequency change versus power amplifier output, a temperature change versus power amplifier output, a conservative collector bias versus adjacent channel leakage ratio inefficiencies and calibration inefficiencies. The feedback path may include a receive downconverter. The receive downconverter may

include inphase/quadrature sampling. The power train amplification stage may be part of a transmitter in a wireless communication device or in a base station.

A method for adjusting a bias voltage to a power amplifier is also described. A transmit signal is obtained from a power amplifier. A feedback signal is obtained from the transmit signal. The feedback signal is provided to a pulse density modulator. An output of the pulse density modulator is used to control a switched mode power supply. A bias voltage applied to the power amplifier is adjusted using the switched mode power supply.

The method may be performed by a wireless communication device or a base station. The feedback signal may be obtained using a power detector. The power detector may be continuously monitored in online mode to keep updating the bias voltage for the power amplifier. The power detector may maintain calibration tables for the power amplifier. Maintaining calibration tables for the power amplifier may include transmitting using a gain control word to control a transceiver, incrementally adjusting the bias voltage to obtain a new bias voltage, estimating a new power amplifier output using a power estimation curve and updating the new bias voltage and the new power amplifier output in the calibration tables.

It may be determined that a mapping of the new power amplifier output and the new bias voltage is close to a characterized table. The method may include periodically checking that the new power amplifier output is accurate via the feedback signal. The feedback signal may be obtained using a receive downconverter. The receive downconverter may include inphase/quadrature sampling. The method may reduce inefficiencies in the power amplifier using dynamic voltage scaling. The inefficiencies may include at least one of a frequency change versus power amplifier output, a temperature change versus power amplifier output, a conservative collector bias versus adjacent channel leakage ratio inefficiencies and calibration inefficiencies.

An apparatus for adjusting a bias voltage to a power amplifier is described. The apparatus includes means for obtaining a transmit signal from a power amplifier. The apparatus also includes means for obtaining a feedback signal from the transmit signal. The apparatus further includes means for providing the feedback signal to a pulse density modulator. The apparatus also includes means for using an output of the pulse density modulator to control a switched mode power supply. The apparatus further includes means for adjusting a bias voltage applied to the power amplifier using the switched mode power supply.

A computer-program product for adjusting a bias voltage to a power amplifier is also described. The computer-program product includes a non-transitory computer-readable medium having instructions thereon. The instructions include code for causing a wireless device to obtain a transmit signal from a power amplifier. The instructions also include code for causing the wireless device to obtain a feedback signal from the transmit signal. The instructions further include code for causing the wireless device to provide the feedback signal to a pulse density modulator. The instructions also include code for causing the wireless device to use an output of the pulse density modulator to control a switched mode power supply. The instructions further include code for causing the wireless device to adjust a bias voltage applied to the power amplifier using the switched mode power supply.

BRIEF DESCRIPTION OF THE DRAWINGS

FIG. 1 shows a wireless communication system with multiple wireless devices;

FIG. 2 is a block diagram illustrating a transmitter for use in the present systems and methods;

FIG. 3 is a block diagram illustrating a power train amplification (APT) stage for use in the present systems and methods;

FIG. 4 is a flow diagram of a method for adjusting a bias voltage Vcc to a power amplifier (PA) using a feedback path through a power detector (PDET);

FIG. 5 is a block diagram illustrating another power train amplification (APT) stage for use in the present systems and methods;

FIG. 6 is a flow diagram of a method for adjusting a bias voltage Vcc to a power amplifier (PA) using a feedback path through a receive Rx downconverter;

FIG. 7 is a flow diagram of a method for updating calibration tables used to adjust the bias voltage Vcc to a power amplifier (PA);

FIG. 8 is a graph illustrating a power estimation curve as a function of bias voltage Vcc;

FIG. 9 illustrates certain components that may be included within a wireless communication device; and

FIG. 10 illustrates certain components that may be included within a base station.

DETAILED DESCRIPTION

The 3rd Generation Partnership Project (3GPP) is a collaboration between groups of telecommunications associations that aims to define a globally applicable 3rd generation (3G) mobile phone specification. 3GPP Long Term Evolution (LTE) is a 3GPP project aimed at improving the Universal Mobile Telecommunications System (UMTS) mobile phone standard. The 3GPP may define specifications for the next generation of mobile networks, mobile systems and mobile devices. In 3GPP LTE, a mobile station or device may be referred to as a "user equipment" (UE).

3GPP specifications are based on evolved Global System for Mobile Communications (GSM) specifications, which are generally known as the Universal Mobile Telecommunications System (UMTS). 3GPP standards are structured as releases. Discussion of 3GPP thus frequently refers to the functionality in one release or another. For example, Release 99 specifies the first UMTS third generation (3G) networks, incorporating a CDMA air interface. Release 6 integrates operation with wireless local area networks (LAN) networks and adds High Speed Uplink Packet Access (HSUPA). Release 8 introduces dual downlink carriers and Release 9 extends dual carrier operation to uplink for UMTS.

CDMA2000 is a family of 3rd generation (3G) technology standards that use code division multiple access (CDMA) to send voice, data and signaling between wireless devices. CDMA2000 may include CDMA2000 1x, CDMA2000 EV-DO Rev. 0, CDMA2000 EV-DO Rev. A and CDMA2000 EV-DO Rev. B. 1x or 1xRTT refers to the core CDMA2000 wireless air interface standard. 1x more specifically refers to 1 times Radio Transmission Technology and indicates the same radio frequency (RF) bandwidth as used in IS-95. 1xRTT adds 64 additional traffic channels to the forward link. EV-DO refers to Evolution-Data Optimized. EV-DO is a telecommunications standard for the wireless transmission of data through radio signals.

FIG. 1 shows a wireless communication system 100 with multiple wireless devices. Wireless communication systems 100 are widely deployed to provide various types of communication content such as voice, data and so on. A wireless device may be a base station 102 or a wireless communication device 104.

A base station 102 is a station that communicates with one or more wireless communication devices 104. A base station

102 may also be referred to as, and may include some or all of the functionality of, an access point, a broadcast transmitter, a NodeB, an evolved NodeB, etc. The term "base station" will be used herein. Each base station 102 provides communication coverage for a particular geographic area. A base station 102 may provide communication coverage for one or more wireless communication devices 104. The term "cell" can refer to a base station 102 and/or its coverage area depending on the context in which the term is used.

A wireless communication device 104 may also be referred to as, and may include some or all of the functionality of, a terminal, an access terminal, a user equipment (UE), a subscriber unit, a station, etc. A wireless communication device 104 may be a cellular phone, a personal digital assistant (PDA), a wireless device, a wireless modem, a handheld device, a laptop computer, a tablet computer, a PC card, compact flash, an external or internal modem, a wireline phone, etc. A wireless communication device 104 may be mobile or stationary. A wireless communication device 104 may communicate with zero, one or multiple base stations 102 on a downlink 106 and/or an uplink 108 at any given moment. The downlink 106 (or forward link) refers to the communication link from a base station 102 to a wireless communication device 104, and the uplink 108 (or reverse link) refers to the communication link from a wireless communication device 104 to a base station 102. Uplink 108 and downlink 106 may refer to the communication link or to the carriers used for the communication link.

Communications in a wireless communication system 100 (e.g., a multiple-access system) may be achieved through transmissions over a wireless link. Such a communication link may be established via a single-input and single-output (SISO) or a multiple-input and multiple-output (MIMO) system. A multiple-input and multiple-output (MIMO) system includes transmitter(s) and receiver(s) equipped, respectively, with multiple (NT) transmit antennas and multiple (NR) receive antennas for data transmission. SISO systems are particular instances of a multiple-input and multiple-output (MIMO) system. The multiple-input and multiple-output (MIMO) system can provide improved performance (e.g., higher throughput, greater capacity or improved reliability) if the additional dimensionalities created by the multiple transmit and receive antennas are utilized.

The wireless communication system 100 may utilize both single-input and multiple-output (SIMO) and multiple-input and multiple-output (MIMO). The wireless communication system 100 may be a multiple-access system capable of supporting communication with multiple wireless communication devices 104 by sharing the available system resources (e.g., bandwidth and transmit power). Examples of such multiple-access systems include code division multiple access (CDMA) systems, wideband code division multiple access (W-CDMA) systems, time division multiple access (TDMA) systems, frequency division multiple access (FDMA) systems, orthogonal frequency division multiple access (OFDMA) systems, single-carrier frequency division multiple access (SC-FDMA) systems, 3rd Generation Partnership Project (3GPP) Long Term Evolution (LTE) systems and spatial division multiple access (SDMA) systems.

A wireless device may include a transmitter 110a-b and a receiver 114a-b. In one configuration, the transmitter 110 and the receiver 114 may be collectively referred to as a transceiver. A transmitter 110 may include a power train amplification (APT) stage 112a-b. The power train amplification (APT) stage 112 may amplify signals prior to transmission. A power train amplification (APT) stage 112 may be included in a transmitter 110a on the wireless communication device 104

and a transmitter **110b** on the base station **102**. The power train amplification (APT) stage **112** may use a Dynamic Voltage Scaling (DVS) scheme to conserve power and increase performance

In one configuration, an open loop calibration of Dynamic Voltage Scaling (DVS) schemes may be used. However, due to a conservative estimate of the voltage profile across power, an open loop calibration of Dynamic Voltage Scaling (DVS) schemes may have inefficiencies. For example, the voltage profile may be conservative to account for part-to-part and frequency/temperature variations. Feedback based Dynamic Voltage Scaling (DVS) schemes may be used in mission mode to impart a more aggressive voltage profile to increase efficiency. An open loop power train amplification (APT) stage **112** may have an inefficient frequency change versus the output of a power amplifier (PA) Pout. An open loop power train amplification (APT) stage **112** may also have an inefficient temperature change versus the output of the power amplifier (PA) Pout. Furthermore, an open loop power train amplification (APT) stage **112** may have a conservative collector bias versus the adjacent channel leakage ratio (ACLR). An open loop power train amplification (APT) stage **112** may have calibration inefficiencies. A closed loop power train amplification (APT) stage **112** may address all of these inefficiencies.

FIG. 2 is a block diagram illustrating a transmitter **210** for use in the present systems and methods. The transmitter **210** of FIG. 2 may be one configuration of the transmitters **110a-b** of FIG. 1. The transmitter **210** may include a pulse shaping module **218**. The pulse shaping module **218** may receive a baseband transmit signal **216**. The pulse shaping module **218** may be coupled to a digital-to-analog converter (DAC) **220**. The digital-to-analog converter (DAC) **220** may be coupled to a mixer **222**. The mixer **222** may output a mixed transmit signal **228** to a power train amplification (APT) stage **212**. The power train amplification (APT) stage **212** of FIG. 2 may be one configuration of the power train amplification (APT) stages **112a-b** of FIG. 1. The power train amplification (APT) stage **212** may output a transmit signal **228**. In one configuration, the power train amplification (APT) stage **212** may output the transmit signal **228** to a duplexer.

FIG. 3 is a block diagram illustrating a power train amplification (APT) stage **312** for use in the present systems and methods. The power train amplification (APT) stage **312** of FIG. 3 may be one configuration of the power train amplification (APT) stages **112a-b** of FIG. 1. The power train amplification (APT) stage **312** may use a closed loop feedback path that includes a power detector (PDET) **346**.

The power train amplification (APT) stage **312** may include a pulse density modulator (PDM) **330**. The pulse density modulator (PDM) **330** may receive a sigma-delta digital signal **349** from a modem. The output of the pulse density modulator (PDM) **330** may be coupled to a filter **332**. In one configuration, the filter **332** may be a RC-RC filter. The filter **332** may output a control voltage Vcontrol **334** to a switched mode power supply (SMPS) **336**. The switched mode power supply (SMPS) **336** may also receive a battery voltage VBatt **338**. The switched mode power supply (SMPS) **336** may output a bias voltage Vcc **340** to a power amplifier (PA) **344**. The bias voltage Vcc **340** may control the power output of the power amplifier (PA) **344**. A power estimate for the power amplifier (PA) **344** may be obtained from a ΔP (change in power) versus ΔV (change in voltage) curve. One example of a power estimate curve is illustrated in FIG. 8.

The input to the power amplifier (PA) **344** may be coupled to the output of a driver amplifier (DA) **342**. The driver amplifier (DA) **342** may receive a mixed transmit signal **324** from

a mixer **222**. The power amplifier (PA) **344** may output a transmit signal **328**. The transmit signal **328** may be passed through a power detector (PDET) **346** to obtain a feedback signal **348**. The power detector (PDET) **346** may be a very accurate power measurement device. The power detector (PDET) **346** may need to have reference Pout calibration performed. The power detector (PDET) **346** may also require continuous monitoring in online mode to keep updating the bias for the power amplifier (PA) **344**. The power detector (PDET) **346** may update calibration tables **326** appropriately. The power detector (PDET) **346** may output a feedback signal **348** to the pulse density modulator (PDM) **330**.

The power detector (PDET) **346** may be in continuous use. In one configuration, the power detector (PDET) **346** may be used for the 7-8 decibels (dB) of the power amplifier (PA) **344** range. The battery life impact may then have less of an impact at the top of the 7-8 dB range. The use of the power detector (PDET) **346** may result in no estimation of the adjacent channel leakage ratio (ACLR) and no pre-distortion. An automatic gain control (AGC) (not shown) may control the driver amplifier (DA) **342**, the power amplifier (PA) **344** and other blocks in the transmit (Tx) chain.

FIG. 4 is a flow diagram of a method **400** for adjusting a bias voltage Vcc **340** to a power amplifier (PA) **344** using a feedback path through a power detector (PDET) **346**. The method **400** may be performed by a wireless device. The wireless device may be a base station **102** or a wireless communication device **104**. In one configuration, the method **400** may be performed by a transmitter **110** on the wireless device.

The wireless device may obtain **402** a transmit signal **328** from a power amplifier (PA) **344**. The wireless device may obtain **404** a feedback signal **348** from the transmit signal **328** using a power detector (PDET) **346**. The wireless device may provide **406** the feedback signal **348** to a pulse density modulator (PDM) **330**. The wireless device may use **408** an output of the pulse density modulator (PDM) **330** to control a switched mode power supply (SMPS) **336**. The wireless device may adjust **410** a bias voltage Vcc **340** of the power amplifier (PA) **344** using the switched mode power supply (SMPS) **336**. The bias voltage Vcc **340** may be adjusted to remove the power train amplification (APT) slack over frequency and temperature without the need for extra calibration. By adjusting the bias voltage Vcc **340**, the battery current consumption by the wireless device may be reduced.

FIG. 5 is a block diagram illustrating another power train amplification (APT) stage **512** for use in the present systems and methods. The power train amplification (APT) stage **512** of FIG. 5 may be one configuration of the power train amplification (APT) stages **112a-b** of FIG. 1. The power train amplification (APT) stage **512** may use a closed loop feedback path that includes a receive Rx downconverter **550**.

The power train amplification (APT) stage **512** may include a pulse density modulator (PDM) **530**. The pulse density modulator (PDM) **530** may receive a sigma-delta digital signal **549** from a modem. The output of the pulse density modulator (PDM) **530** may be coupled to a filter **532**. In one configuration, the filter **532** may be an RC-RC filter. The filter **532** may output a control voltage Vcontrol **534** to a switched mode power supply (SMPS) **536**. The switched mode power supply (SMPS) **536** may also receive a battery voltage VBatt **538**. The switched mode power supply (SMPS) **536** may output a bias voltage Vcc **540** to a power amplifier (PA) **544**. The bias voltage Vcc **540** may control the power output versus voltage output for the power amplifier (PA) **544**. As discussed above, a power estimate for the power amplifier (PA) **544** may be obtained from a power estimate curve that

plots ΔP (change in power) versus ΔV (change in voltage). One example of a power estimate curve is illustrated in FIG. 8.

The input to the power amplifier (PA) 544 may be coupled to the output of a driver amplifier (DA) 542. The driver amplifier (DA) 542 may receive a mixed transmit signal 524 from a mixer 222. The power amplifier (PA) 544 may output a transmit signal 528. The transmit signal 528 may be passed through a receive Rx downconverter 550. The receive Rx downconverter 550 may include inphase/quadrature (I/Q) sampling 552. The receive Rx downconverter 550 may be a normal receiver chain with looser requirements in terms of noise and linearity. The receive Rx downconverter 550 may include a standard amplifier stage (e.g., a low noise amplifier (LNA)), a mixer (in one configuration the phase lock loop (PLL) and local oscillator (LO) may be shared with the transmitter), an analog baseband filter and an analog-to-digital converter (ADC). The analog-to-digital converter (ADC) may be stand-alone or shred with an analog-to-digital converter (ADC) in the main receiver path and be time multiplexed with the shred analog-to-digital converter (ADC). The receive Rx downconverter 550 may output a feedback signal 548 to the pulse density modulator (PDM) 530. In one configuration, the output of the analog-to-digital converter (ADC) may control the pulse density modulator (PDM) 530 value.

FIG. 6 is a flow diagram of a method 600 for adjusting a bias voltage Vcc 540 to a power amplifier (PA) 544 using a feedback path through a receive Rx downconverter 550. The method 600 may be performed by a wireless device. The wireless device may be a base station 102 or a wireless communication device 104. In one configuration, the method 600 may be performed by a transmitter 110 on the wireless device.

The wireless device may obtain 602 a transmit signal 528 from a power amplifier (PA) 544. The wireless device may obtain 604 a feedback signal 548 from the transmit signal 528 using a receive Rx downconverter 550. The wireless device may provide 606 the feedback signal 548 to a pulse density modulator (PDM) 530. The wireless device may use 608 an output of a pulse density modulator (PDM) 530 to control a switched mode power supply (SMPS) 536. The wireless device may adjust 610 a bias voltage Vcc 540 of the power amplifier (PA) 544 using the switched mode power supply (SMPS) 536. The bias voltage Vcc 540 may be adjusted to remove the power train amplification (APT) slack over frequency and temperature without the need for extra calibration. By adjusting the bias voltage Vcc 540, the battery current consumption by the wireless device may be reduced.

FIG. 7 is a flow diagram of a method 700 for updating calibration tables 326 used to adjust the bias voltage Vcc 340 to a power amplifier (PA) 344. The method 700 may be performed by a wireless device. In one configuration, the wireless device may be a base station 102 or a wireless communication device 104. It may be assumed that a characterized power amplifier (PA) 344 versus bias voltage Vcc 340 profile such as that in Table 1 below is used.

TABLE 1

Switched Mode Power Supply (SMPS) Characterization Table	
Power Amplifier (PA) Output Power (dBm)	Switched Mode Power Supply (SMPS) Output (V) (Bias Voltage Vcc)
16	2.2
17	2.3
18	2.4
19	2.5

TABLE 1-continued

Switched Mode Power Supply (SMPS) Characterization Table	
Power Amplifier (PA) Output Power (dBm)	Switched Mode Power Supply (SMPS) Output (V) (Bias Voltage Vcc)
20	2.6
21	2.8
22	3.1
23	3.4
24	3.4
25	3.4
26	3.4

The wireless device may transmit 702 using a gain control word X. The gain control word X may control a transceiver at this particular instant. For the gain word X, the power amplifier (PA) 344 output may be P (in dBm (the power ratio in dB of the measured power reference to 1 milliwatt (mW))) and the switched mode power supply (SMPS) 336 output (i.e., the bias voltage Vcc 340) may be in volts. The wireless device may adjust 704 a new bias voltage Vnew equal to the bias voltage Vcc 340 plus ΔV (where ΔV is an incremental change in voltage). The wireless device may estimate 706 a new power amplifier (PA) 344 output Pnew equal to a power amplifier (PA) 344 output P plus ΔP (where ΔP is an incremental change in power in dBm) from a power estimation curve (such as that of FIG. 8). The wireless device may then update 708 the new bias voltage Vnew and the new power amplifier (PA) 344 output Pnew in calibration tables 326 on the wireless device. The wireless device may ensure that the calibration tables 326 are always monotonic and have a certain minimum step size with the adjacent pulse density modulator (PDM) 330.

The wireless device may determine 710 whether the power amplifier (PA) 344 output P and the bias voltage Vcc 340 mapping is close to a switched mode power supply (SMPS) characterization table (such as that used in Table 1 above). If the power amplifier (PA) 344 output P and the bias voltage Vcc 340 mapping is not close to the characterized table, the wireless device may transmit 702 using a gain control word X to control the transceiver. The power units and the switched mode power supply (SMPS) pulse density modulator (PDM) units may be discrete digital quantities. If the power amplifier (PA) 344 output P and the bias voltage Vcc 340 mapping is close to the characterized table, the wireless device may periodically check 712 that the estimated power are accurate via the feedback signal 348. Until an exact match is found, the tables may continue to be updated.

To calibrate the power train amplification (APT) stage 112, two power sweeps may be performed. A first power sweep may be performed at a fixed bias. The first power sweep may establish Pout to RGI mapping. A second power sweep may be performed with the power train amplification (APT) voltages (i.e., using a variable bias voltage Vcc 340). The second power sweep may establish RGI to switched mode power supply (SMPS) 336 to Pout mapping.

FIG. 8 is a graph illustrating a power estimation curve 800 as a function of bias voltage Vcc 540. The power estimation curve 800 may be obtained from a Dynamic Voltage Scaling (DVS) calibration scheme. Other power estimation curves may also be used. The power estimation curve illustrates the change in delta voltage ΔV (i.e., the change in the bias voltage Vcc 840) and the corresponding change in delta power ΔP output by the power amplifier (PA) 344.

FIG. 9 illustrates certain components that may be included within a wireless communication device 904. The wireless communication device 904 may be an access terminal, a

mobile station, a user equipment (UE), etc. The wireless communication device **904** includes a processor **903**. The processor **903** may be a general purpose single- or multi-chip microprocessor (e.g., an ARM), a special purpose microprocessor (e.g., a digital signal processor (DSP)), a microcontroller, a programmable gate array, etc. The processor **903** may be referred to as a central processing unit (CPU). Although just a single processor **903** is shown in the wireless communication device **904** of FIG. 9, in an alternative configuration, a combination of processors (e.g., an ARM and DSP) could be used.

The wireless communication device **904** also includes memory **905**. The memory **905** may be any electronic component capable of storing electronic information. The memory **905** may be embodied as random access memory (RAM), read-only memory (ROM), magnetic disk storage media, optical storage media, flash memory devices in RAM, on-board memory included with the processor, EPROM memory, EEPROM memory, registers and so forth, including combinations thereof.

Data **907a** and instructions **909a** may be stored in the memory **905**. The instructions **909a** may be executable by the processor **903** to implement the methods disclosed herein. Executing the instructions **909a** may involve the use of the data **907a** that is stored in the memory **905**. When the processor **903** executes the instructions **909**, various portions of the instructions **909b** may be loaded onto the processor **903**, and various pieces of data **907b** may be loaded onto the processor **903**.

The wireless communication device **904** may also include a transmitter **911** and a receiver **913** to allow transmission and reception of signals to and from the wireless communication device **904** via an antenna **917**. The transmitter **911** and receiver **913** may be collectively referred to as a transceiver **915**. The wireless communication device **904** may also include (not shown) multiple transmitters, multiple antennas, multiple receivers and/or multiple transceivers.

The wireless communication device **904** may include a digital signal processor (DSP) **921**. The wireless communication device **904** may also include a communications interface **923**. The communications interface **923** may allow a user to interact with the wireless communication device **904**.

The various components of the wireless communication device **904** may be coupled together by one or more buses, which may include a power bus, a control signal bus, a status signal bus, a data bus, etc. For the sake of clarity, the various buses are illustrated in FIG. 9 as a bus system **919**.

FIG. 10 illustrates certain components that may be included within a base station **1002**. A base station **1002** may also be referred to as, and may include some or all of the functionality of, an access point, a broadcast transmitter, a NodeB, an evolved NodeB, etc. The base station **1002** includes a processor **1003**. The processor **1003** may be a general purpose single- or multi-chip microprocessor (e.g., an ARM), a special purpose microprocessor (e.g., a digital signal processor (DSP)), a microcontroller, a programmable gate array, etc. The processor **1003** may be referred to as a central processing unit (CPU). Although just a single processor **1003** is shown in the base station **1002** of FIG. 10, in an alternative configuration, a combination of processors (e.g., an ARM and DSP) could be used.

The base station **1002** also includes memory **1005**. The memory **1005** may be any electronic component capable of storing electronic information. The memory **1005** may be embodied as random access memory (RAM), read-only memory (ROM), magnetic disk storage media, optical storage media, flash memory devices in RAM, on-board memory

included with the processor, EPROM memory, EEPROM memory, registers and so forth, including combinations thereof.

Data **1007a** and instructions **1009a** may be stored in the memory **1005**. The instructions **1009a** may be executable by the processor **1003** to implement the methods disclosed herein. Executing the instructions **1009a** may involve the use of the data **1007a** that is stored in the memory **1005**. When the processor **1003** executes the instructions **1009a**, various portions of the instructions **1009b** may be loaded onto the processor **1003**, and various pieces of data **1007b** may be loaded onto the processor **1003**.

The base station **1002** may also include a transmitter **1011** and a receiver **1013** to allow transmission and reception of signals to and from the base station **1002**. The transmitter **1011** and receiver **1013** may be collectively referred to as a transceiver **1015**. An antenna **1017** may be electrically coupled to the transceiver **1015**. The base station **1002** may also include (not shown) multiple transmitters, multiple receivers, multiple transceivers and/or additional antennas.

The base station **1002** may include a digital signal processor (DSP) **1021**. The base station **1002** may also include a communications interface **1023**. The communications interface **1023** may allow a user to interact with the base station **1002**.

The various components of the base station **1002** may be coupled together by one or more buses, which may include a power bus, a control signal bus, a status signal bus, a data bus, etc. For the sake of clarity, the various buses are illustrated in FIG. 10 as a bus system **1019**.

The term “determining” encompasses a wide variety of actions and, therefore, “determining” can include calculating, computing, processing, deriving, investigating, looking up (e.g., looking up in a table, a database or another data structure), ascertaining and the like. Also, “determining” can include receiving (e.g., receiving information), accessing (e.g., accessing data in a memory) and the like. Also, “determining” can include resolving, selecting, choosing, establishing and the like.

The phrase “based on” does not mean “based only on,” unless expressly specified otherwise. In other words, the phrase “based on” describes both “based only on” and “based at least on.”

The term “processor” should be interpreted broadly to encompass a general purpose processor, a central processing unit (CPU), a microprocessor, a digital signal processor (DSP), a controller, a microcontroller, a state machine and so forth. Under some circumstances, a “processor” may refer to an application specific integrated circuit (ASIC), a programmable logic device (PLD), a field programmable gate array (FPGA), etc. The term “processor” may refer to a combination of processing devices, e.g., a combination of a DSP and a microprocessor, a plurality of microprocessors, one or more microprocessors in conjunction with a DSP core, or any other such configuration.

The term “memory” should be interpreted broadly to encompass any electronic component capable of storing electronic information. The term memory may refer to various types of processor-readable media such as random access memory (RAM), read-only memory (ROM), non-volatile random access memory (NVRAM), programmable read-only memory (PROM), erasable programmable read-only memory (EPROM), electrically erasable PROM (EEPROM), flash memory, magnetic or optical data storage, registers, etc. Memory is said to be in electronic communication with a processor if the processor can read information from and/or

write information to the memory. Memory that is integral to a processor is in electronic communication with the processor.

The terms “instructions” and “code” should be interpreted broadly to include any type of computer-readable statement(s). For example, the terms “instructions” and “code” may refer to one or more programs, routines, sub-routines, functions, procedures, etc. “Instructions” and “code” may comprise a single computer-readable statement or many computer-readable statements.

The functions described herein may be implemented in software or firmware being executed by hardware. The functions may be stored as one or more instructions on a computer-readable medium. The terms “computer-readable medium” or “computer-program product” refers to any tangible storage medium that can be accessed by a computer or a processor. By way of example, and not limitation, a computer-readable medium may comprise RAM, ROM, EEPROM, CD-ROM or other optical disk storage, magnetic disk storage or other magnetic storage devices, or any other medium that can be used to carry or store desired program code in the form of instructions or data structures and that can be accessed by a computer. Disk and disc, as used herein, includes compact disc (CD), laser disc, optical disc, digital versatile disc (DVD), floppy disk and Blu-ray® disc where disks usually reproduce data magnetically, while discs reproduce data optically with lasers. It should be noted that a computer-readable medium may be tangible and non-transitory. The term “computer-program product” refers to a computing device or processor in combination with code or instructions (e.g., a “program”) that may be executed, processed or computed by the computing device or processor. As used herein, the term “code” may refer to software, instructions, code or data that is/are executable by a computing device or processor.

Software or instructions may also be transmitted over a transmission medium. For example, if the software is transmitted from a website, server, or other remote source using a coaxial cable, fiber optic cable, twisted pair, digital subscriber line (DSL), or wireless technologies such as infrared, radio and microwave, then the coaxial cable, fiber optic cable, twisted pair, DSL, or wireless technologies such as infrared, radio and microwave are included in the definition of transmission medium.

The methods disclosed herein comprise one or more steps or actions for achieving the described method. The method steps and/or actions may be interchanged with one another without departing from the scope of the claims. In other words, unless a specific order of steps or actions is required for proper operation of the method that is being described, the order and/or use of specific steps and/or actions may be modified without departing from the scope of the claims.

Further, it should be appreciated that modules and/or other appropriate means for performing the methods and techniques described herein, such as those illustrated by FIGS. 4, 6 and 7, can be downloaded and/or otherwise obtained by a device. For example, a device may be coupled to a server to facilitate the transfer of means for performing the methods described herein. Alternatively, various methods described herein can be provided via a storage means (e.g., random access memory (RAM), read-only memory (ROM), a physical storage medium such as a compact disc (CD) or floppy disk, etc.), such that a device may obtain the various methods upon coupling or providing the storage means to the device. Moreover, any other suitable technique for providing the methods and techniques described herein to a device can be utilized.

It is to be understood that the claims are not limited to the precise configuration and components illustrated above. Various modifications, changes and variations may be made in the arrangement, operation and details of the systems, methods and apparatus described herein without departing from the scope of the claims.

What is claimed is:

1. A power train amplification stage, comprising:

a power amplifier;
a switched mode power supply that provides a bias voltage to the power amplifier;
a pulse density modulator; and
a feedback path from the power amplifier to the pulse density modulator, wherein the feedback path comprises a receive downconverter.

2. The power train amplification stage of claim 1, wherein the pulse density modulator controls the switched mode power supply.

3. The power train amplification stage of claim 1, wherein the pulse density modulator receives a sigma-delta digital signal.

4. The power train amplification stage of claim 1, wherein the power train amplification stage uses dynamic voltage scaling to reduce inefficiencies in the power amplifier.

5. The power train amplification stage of claim 4, wherein the inefficiencies comprise at least one of a frequency change versus power amplifier output, a temperature change versus power amplifier output, a conservative collector bias versus adjacent channel leakage ratio inefficiencies, or calibration inefficiencies.

6. The power train amplification stage of claim 1, wherein the receive downconverter comprises inphase/quadrature sampling.

7. The power train amplification stage of claim 1, wherein the power train amplification stage is part of a transmitter in a wireless communication device.

8. The power train amplification stage of claim 1, wherein the power train amplification stage is part of a transmitter in a base station.

9. A method for adjusting a bias voltage to a power amplifier, the method comprising:

obtaining a transmit signal from a power amplifier;
obtaining a feedback signal from the transmit signal, wherein the feedback signal is obtained using a receive downconverter;
providing the feedback signal to a pulse density modulator;
using an output of the pulse density modulator to control a switched mode power supply; and
adjusting a bias voltage applied to the power amplifier using the switched mode power supply.

10. The method of claim 9, wherein the method is performed by a wireless communication device.

11. The method of claim 9, wherein the method is performed by a base station.

12. A method for adjusting a bias voltage to a power amplifier, the method comprising:

obtaining a transmit signal from a power amplifier;
obtaining a feedback signal from the transmit signal, wherein the feedback signal is obtained using a power detector, the power detector maintaining calibration tables for the power amplifier;
providing the feedback signal to a pulse density modulator;
using an output of the pulse density modulator to control a switched mode power supply; and
adjusting a bias voltage applied to the power amplifier using the switched mode power supply,

13

wherein maintaining calibration tables for the power amplifier comprises:

transmitting using a gain control word to control a transceiver;

incrementally adjusting the bias voltage to obtain a new bias voltage;

estimating a new power amplifier output using a power estimation curve; and

updating the new bias voltage and the new power amplifier output in the calibration tables.

13. The method of claim **12**, further comprising:

determining that a mapping of the new power amplifier output and the new bias voltage is close to a characterized table; and

periodically checking that the new power amplifier output is accurate via the feedback signal.

14. The method of claim **9**, wherein the receive downconverter comprises inphase/quadrature sampling.

15. The method of claim **9**, wherein the method reduces inefficiencies in the power amplifier using dynamic voltage scaling.

16. The method of claim **15**, wherein the inefficiencies comprise at least one of a frequency change versus power amplifier output, a temperature change versus power amplifier output, a conservative collector bias versus adjacent channel leakage ratio inefficiencies, or calibration inefficiencies.

17. An apparatus for adjusting a bias voltage to a power amplifier, comprising:

means for obtaining a transmit signal from a power amplifier;

14

means for obtaining a feedback signal from the transmit signal, wherein the feedback signal is obtained using a receive downconverter;

means for providing the feedback signal to a pulse density modulator;

means for using an output of the pulse density modulator to control a switched mode power supply; and

means for adjusting a bias voltage applied to the power amplifier using the switched mode power supply.

18. The apparatus of claim **17**, wherein the receive downconverter comprises inphase/quadrature sampling.

19. A computer-program product for adjusting a bias voltage to a power amplifier, the computer-program product comprising a non-transitory computer-readable medium having instructions thereon, the instructions comprising:

code for causing a wireless device to obtain a transmit signal from a power amplifier;

code for causing the wireless device to obtain a feedback signal from the transmit signal, wherein the feedback signal is obtained using a receive downconverter;

code for causing the wireless device to provide the feedback signal to a pulse density modulator;

code for causing the wireless device to use an output of the pulse density modulator to control a switched mode power supply; and

code for causing the wireless device to adjust a bias voltage applied to the power amplifier using the switched mode power supply.

20. The computer-program product of claim **19**, wherein the receive downconverter comprises inphase/quadrature sampling.

* * * * *